

Microflush Half Gallon Toilets

Model LF-220 DC Operated



Installation/Service Manual P/N 24155



452 East Hill Road
Willits, CA 95490 USA
Phone: 707.459.5563
Toll Free: 1.800.358.8280

Fax: 707.459.6617
E-mail: info@microphor.com
www.microphor.com
www.wabtec.com

24155.WPD
10/18/01

Thank You!

Thank you for purchasing a Microphor product. Please read this manual completely prior to installation of your Microflush[®] toilet. Microphor General Terms and Conditions Covering Sales apply.

Customer Service

If you have any questions concerning your Microphor product, please contact us:

8:AM-5:PM PST Monday-Friday
Tel: (800) 358-8280 or (707) 459-5563
Fax: (707) 459-6617, 24 hour
Website: www.microphor.com
E-mail: info@microphor.com

Patents

Microflush toilets are covered by one or more of the following U.S. patents 5245710; 4918764; 1280554; 169471 and related foreign patents.

Changes in Design

Continuing a policy of research and development, Microphor reserves the right of price, product or design change without notice or obligation.

Cautions

Do Not Use products containing petroleum distillates or formaldehyde on any rubber parts.

Use only Silicone Lubricants!

Do Not Use any "Loctite" brand adhesive on any plastic or Delrin components as fumes will cause damage to plastic parts.

System vacuum breaker is not intended to be pressurized longer than a normal flushing cycle.

Flush Cycle

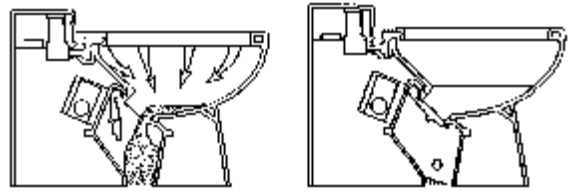

Flush Cycle Operation

The Model LF-220 Microflush Toilet is an electrically operated drop-through type toilet using approximately two quarts of water per flush. Wastewater is flushed from the bowl through a Hopper and drops directly into a holding tank. A Flapper valve at the bottom of the bowl holds fresh water in the bowl and seals out odors from the holding tank.

1. When the flush lever is operated, a motor-driven cam begins to turn which opens the Flapper valve at the bottom of the bowl, allowing the wastewater to flow down into a holding tank. Simultaneously, the water solenoid valve opens, allowing fresh water to flow from the rim and rinse the bowl. The cam continues to turn and the Flapper will close again after approximately 4-5 seconds.
2. After the Flapper has closed, fresh water continues to enter the bowl to a predetermined level until the Timer closes the solenoid valve. An adjustment on the Timer allows adjustment of the water level in the bowl to compensate for water pressure fluctuations. A vacuum breaker is provided as an anti-siphon device.

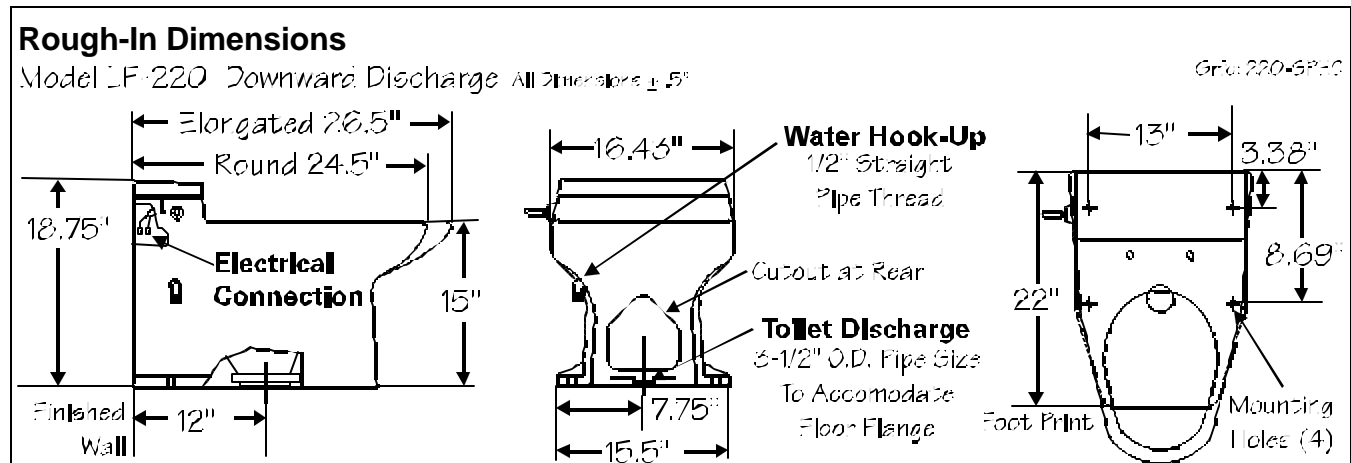

Installation

Refer to Rough-In Dimensions

Note: This toilet is a drop-thru unit. No horizontal waste line runs may be utilized. Contact the factory for specific application data.

Mounting Toilet

Note: Seat must be installed prior to mounting toilet against wall.

Turn toilet upside-down and place enclosed Wax Ring (P/N 27208) or optional Odor Shut-er™, P/N40052-3, onto the bottom mounting flange of the toilet hopper. Carefully turn toilet right-side up and place over the center of a standard floor discharge flange. Press toilet down firmly and evenly to form a seal between the wax ring and the floor flange. Mount the toilet to the floor with the four Closet Screws and install Bolt Caps over the closet screws (both provided).

Electrical Connection

See Rough-In Dimensions and Exploded View. Connect 12 volt DC power source to the insulated .25" spade connector near the Timer and Thermal Circuit Breaker: red wire to positive (+), black wire to negative (-).

Water Connection

See Rough-In Dimensions.

Connect fresh water from an angle stop to the 1/2" threaded water supply connection on the side of the bowl installing Filter Screen (P/N 29146). Take care not to cross the threads. **Incoming water pressure must be between 20-50 psi, with a minimum flow rate of 2.5 GPM at the toilet. Ideal water pressure is 35 psi at the toilet.** Be sure water lines are free of debris before connecting water supply to toilet. Water supply to the toilet is to be 1/2" OD plumbed directly to the toilet. Do not install filter(s) in the toilet water supply line.

Water Level

The normal water level is factory pre-set to the top of the Flapper.

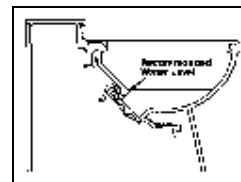

Water Level Adjustment

Locate the timer on the bracket under the china lid. Turn Timer adjustment knob clockwise to increase water level, and counterclockwise to decrease. Do not turn past stops.

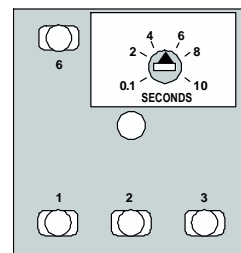

Seat Installation

Place the seat over the bowl opening, so that the mounting hinges on the seat align with the two holes in the bowl just behind the bowl opening. Insert the two seat mounting screws provided with the seat into the hinges' holes and mounting holes in the bowl, from the top. Install washers and mounting nuts provided with the seat, from underneath, and tighten firmly. Install screw head cover tabs or other hardware provided with the seat, per seat manufacturer's instructions.

Maintenance

If the toilet is to be out of service for a period of time, spray 100% silicone on the flapper seal when the flapper is open to prevent it from becoming dry.

Winterizing

Shut OFF water to toilet. Flush toilet three times or until water no longer flows into the bowl. Unhook water supply at angle stop. Empty water in line into receptacle.

Ordering and Factory Assistance

For assistance with procedures not covered in this manual, or to order spare or replacement parts, please call toll-free 1-800-358-8280, 8:00 a.m. to 5:00 p.m. PST, and ask for Commercial Products Division Customer Service.

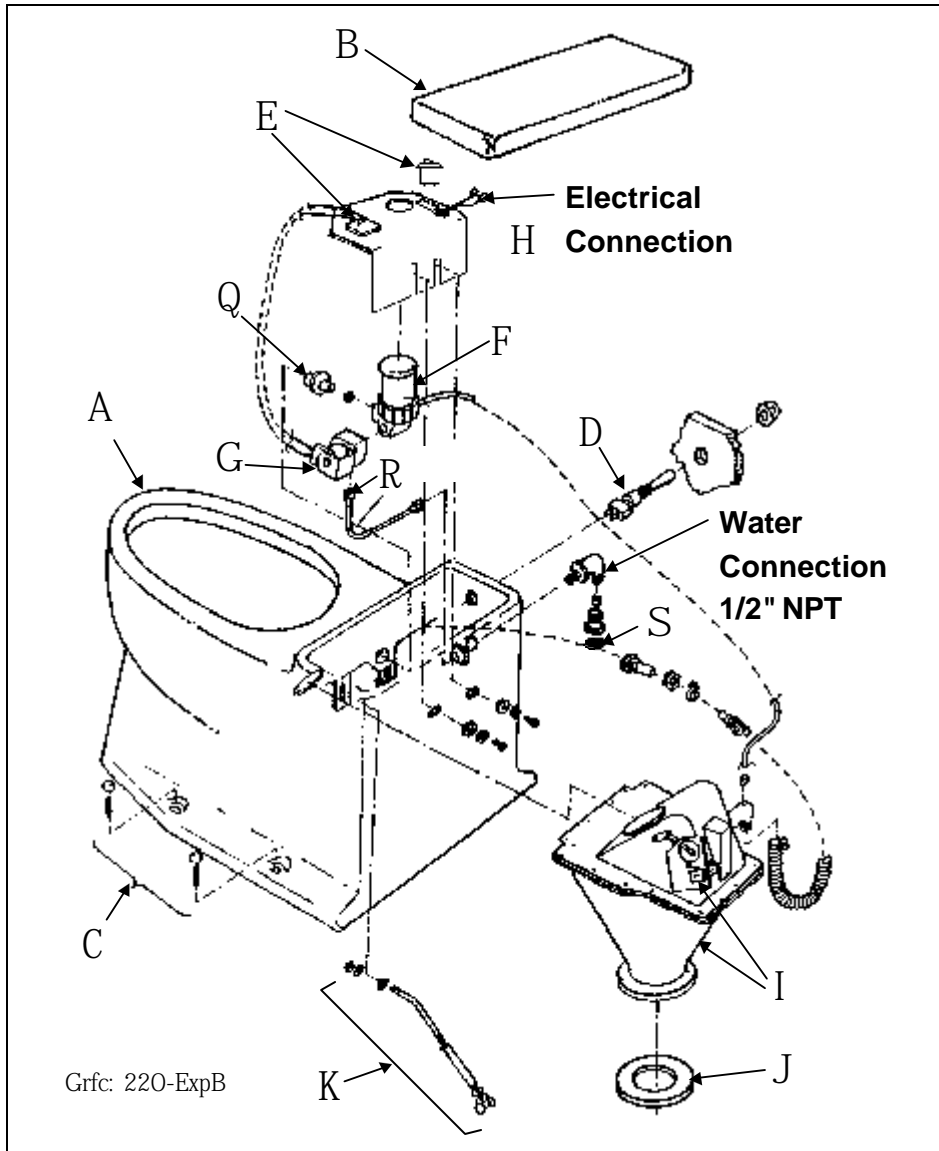

Circuit Breaker Switch allows power to be turned off to service toilet.

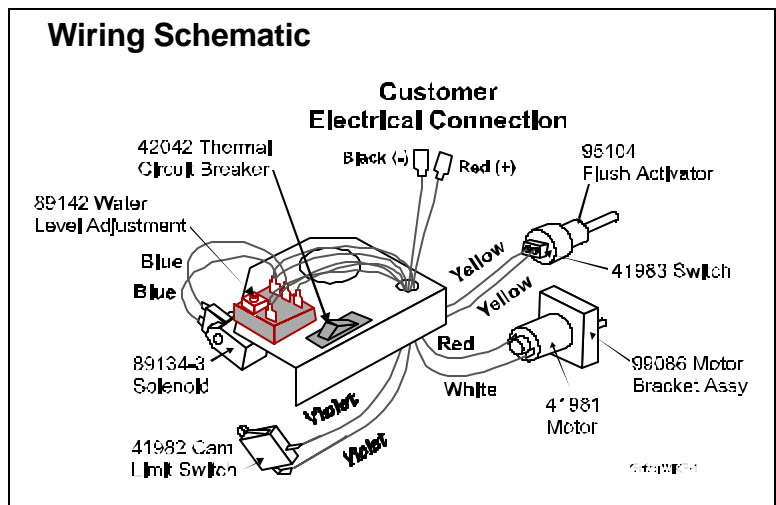
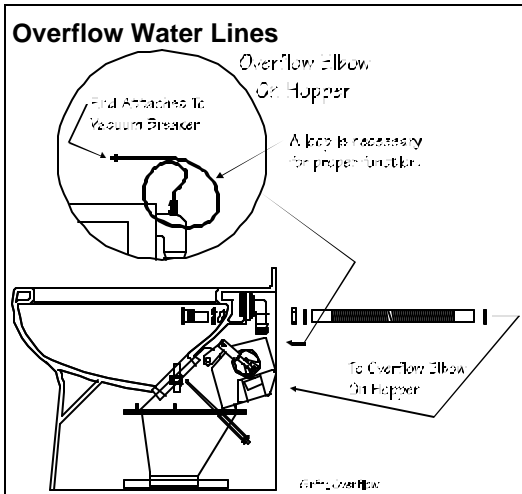

PARTS CHART

	PART	P/N	
A	Bowl - state color	Call	
B	Lid - state color	Call	
C	Mounting Bolts - state color	Call	
D	Flush Activator	Complete Assy	95104
		Switch	41983
		Mounting Nut	00098
		O-Ring	27232
E	Timer Assy	Timer	89142 *
		Thermal Circuit Breaker Switch	42042
F	Vacuum Breaker Assy	<i>see Vacuum Breaker Service</i>	33540
G	Solenoid Valve Assy	<i>see Solenoid Valve Cleaning</i>	89134-3
H	Mounting Bracket		91022
I	Hopper Assy <i>see Hopper</i> <i>see Flapper Adjustment</i>	Hopper Assy without Motor	90056
		Hopper Assy with Motor Assy	90028-3
	Motor Assy <i>see Flapper Adjustment</i> <i>see Clevis exploded view</i> <i>see Wiring Schematic</i>	Motor	41981
		Cam with Set Screw	91865 *
		Motor with Bracket Assy	99086
		Limit Switch	41982 *
J	Floor Seal	Wax Ring	27208
		Odor Shut-er	40052-3
K	Hopper Mounting Assy (J-Bolts)		90899-3
Q	Spud Assy	Complete Assy	96347
		O-Ring	27224
R	Water Supply Tube	Complete Assy	96392
		Elbow	96387
S	Water Filter Screen		92060
K I T S	Flapper Replacement Kit		90066-3 *
	Hopper Adapter Kit		24770-3
	Solenoid Valve Service Kit		40037 *
	Vacuum Breaker Service Kit		95037 *
	Silicone Lubricant		26856
	Master Service Kit		94175

* Items shown with asterisk are in Master Service Kit, P/N 94175.

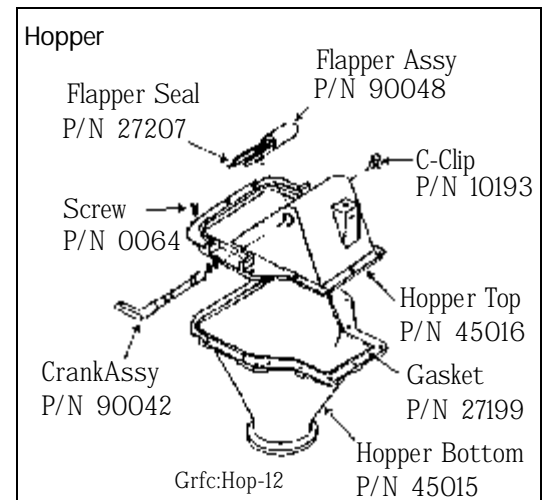
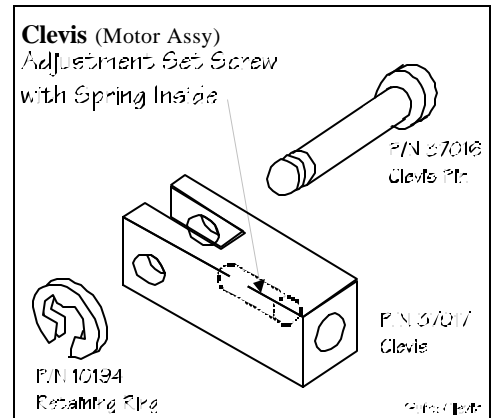

Service Procedures

Before performing any service procedures, turn off water and electrical power to toilet.

Flapper Adjustment

Flapper Replacement Kit, P/N 90066-3

- 1 Remove toilet from floor. Locate flapper operating linkage on the side of the hopper.
- 2 Remove the clevis pin retaining ring. Remove clevis pin.
- 3 Adjust as necessary by turning the 3/8" set screw inside the clevis as required, then replace the clevis pin and retaining ring. Turn clockwise to increase flapper seal tension, counterclockwise to decrease. Inspect the crank arm, clevis and clevis pin for wear; replace if required. Do not turn bolt more than three (3) complete turns.

To Change Flapper Gasket

1. Turn water and air off.
2. Reach behind flapper to grasp gasket tails.
3. Pull tails out of slots to remove old gasket.
4. Installation is the reverse of removal.
5. Tails must be pulled all the way through to insure smooth surface.

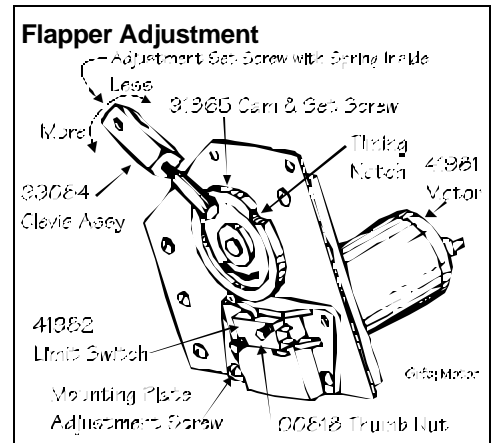

Solenoid Valve Cleaning

Solenoid Service Kit, P/N 40037

- 1 Disconnect the power by removing the two blue wires from the solenoid.
- 2 Disconnect the water supply line at china end.
- 3 Remove two screws securing the solenoid to the mounting bracket.
- 4 Pull solenoid away from the Vacuum Breaker.
- 5 Remove water supply tube.
- 6 Remove four (4) screws from Solenoid Valve Body and remove spring and diaphragm.
- 7 Clean holes in the diaphragm if clogged. Inspect solenoid for debris and clean. Reassemble in reverse order.

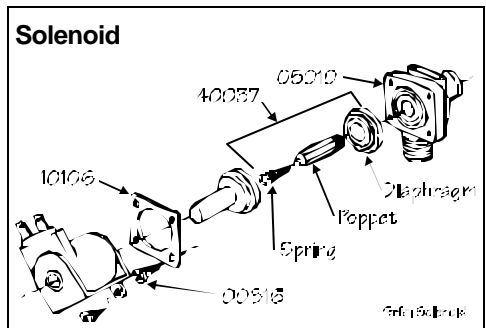

Hopper Removal and Resealing

Hopper Replacement Kit, P/N 24770-3

- 1 Remove toilet from the floor. Place toilet upside down on a sheet of cardboard or other padded material.
- 2 Remove J-bolts nuts from hopper sides - lift the hopper off.
- 3 Remove quad ring between hopper and seal adaptor. Check that the quad ring is not damaged, replace quad ring if necessary.
- 4 Reassemble in reverse order.

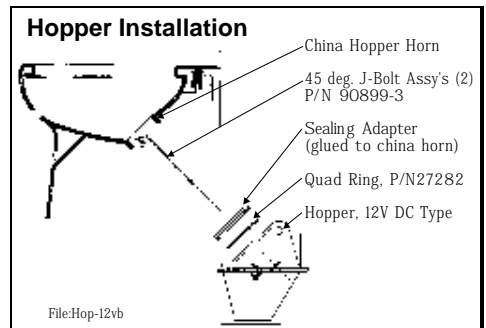

Vacuum Breaker Service

Vacuum Breaker Service Kit, P/N 95037

- 1 If water is visible at the top of the vacuum breaker during operation, apply some silicone lubricant to the underside of the white float and to the O-Ring located at the upper end of the body.
- 2 To disassemble the vacuum breaker, remove the snap-on cap and unscrew body from the bracket. The white float inside can now be removed.
- 3 No service procedures are required for the lower portion of the vacuum breaker.

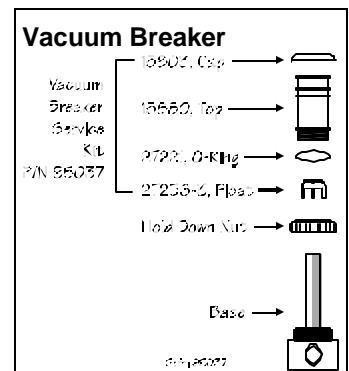

Troubleshooting Guide

Problems	Cause	Remedy
Water drains from bowl	Nicks or obstructions on Flapper seat.	Replace Flapper, Service Kit P/N 90066-3.
	Insufficient Flapper tension	See Flapper Adjustment
	Flapper seal worn or damaged.	Replace Flapper - Kit 90066-3
Water level too high.	Water level control out of adjustment.	Turn Level Adjustment 1/8 turn at a time to raise or lower water level; Clockwise to raise, Counterclockwise to lower.
	Fluctuating water pressure	Regulate water pressure.
	Timer malfunction.	Replace Timer - Reference Timer Drawing
Water continues to run.	Obstruction in water Solenoid Valve.	Remove and inspect Solenoid Valve - see Solenoid Valve Cleaning
Toilet continues to cycle after initial flush cycle is complete - or only partially cycles.	A cracked cam.	Replace Cam - reference Flapper Adjustment Drawing
	Defective Cam Switch; switch out of adjustment.	Adjust or replace Cam Switch - reference Flapper Adjustment Drawing
	Defective Timer	Disconnect either purple wire at limit switch. If toilet continues to cycle, the timer is defective. If the toilet stops cycling, the limit switch either is not adjusted properly or is faulty.
Water leaking on floor.	The hopper has been jarred loose from the bowl.	Reseal Hopper - see Hopper Removal/Reseal
	Defective wax ring at toilet to floor connection.	Replace the wax ring.
	Loose water supply connection at toilet.	Disconnect water line to toilet, add Teflon tape to threads, reconnect.
No water.	Water turned off.	Turn water on.
	Water inlet filter screen clogged.	Clean water inlet filter screen.
	No power to valve.	Check for DC power at Solenoid Valve during flush cycle.
	Defective Timer.	Check Timer operation - replace if necessary.
Toilet doesn't activate.	No power.	Restore power.
	Tripped Circuit Breaker.	Reset Circuit Breaker Switch. Determine cause of tripped breaker if possible before operating toilet.
	Disconnected wires.	Check all wiring connections.
Water is visible at Vacuum Breaker when flushed.	Insufficient lubrication; Worn vacuum breaker seal.	Service Vacuum Breaker, Kit P/N 95037.

If you have any questions or need assistance, call: (800) 358-8280.

Changes in Design: Continuing a policy of research and development, Microphor reserves the right of price, product, or design change without notice or obligation.