

## Microflush Half Gallon Toilets

### Model LF-320 Air Operated



### Installation/Service Manual P/N 24157



452 East Hill Road  
Willits, CA 95490 USA  
Phone: 707.459.5563  
Toll Free: 1.800.358.8280

Fax: 707.459.6617  
E-mail: [info@microphor.com](mailto:info@microphor.com)  
[www.microphor.com](http://www.microphor.com)  
[www.wabtec.com](http://www.wabtec.com)

24157.WPD  
3/27/02

**ROUGH-IN DIMENSIONS ± 0.5"**

**LF-320 Rear Discharge**

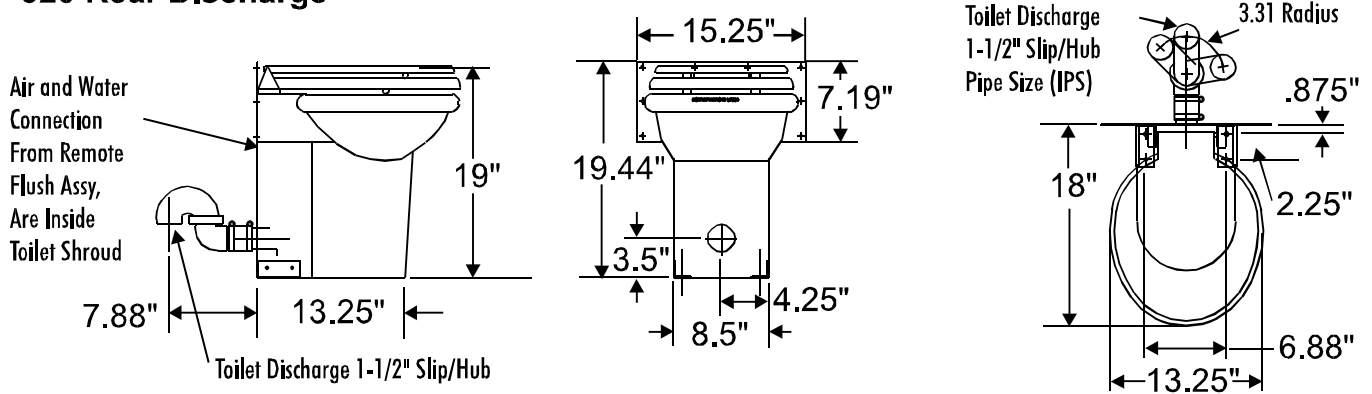

**Remote Flush Rough-In**

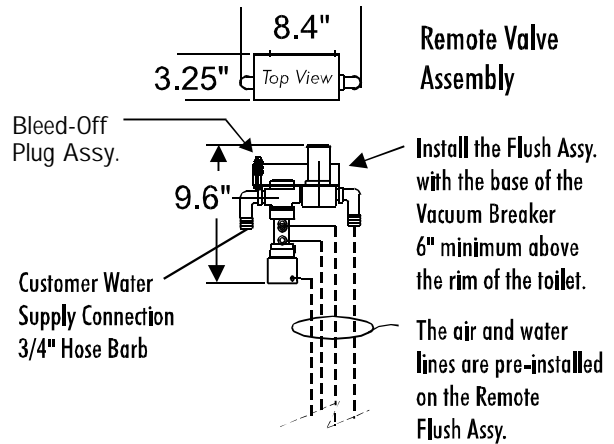
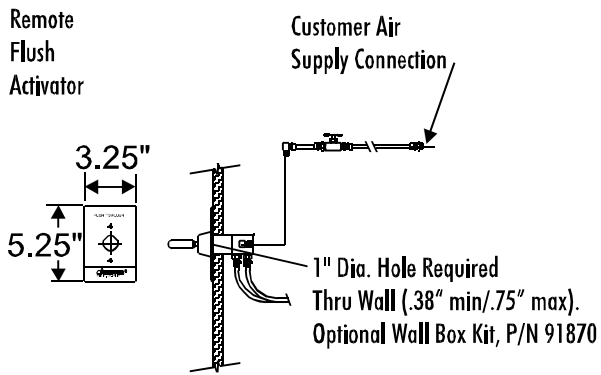

THE MAXIMUM WATER LINE DISTANCE BETWEEN THE TOILET AND THE REMOTE FLUSH ASSY IS SIX (6) FEET.

Grfc: 320-spec

**How Microflush Toilets Operate**

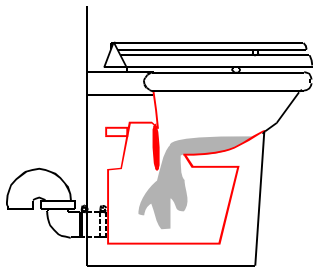

When the flush button is pressed the flapper opens, allowing wastewater to flow into the hopper. Clean water enters the bowl from the rim to thoroughly wash the bowl.

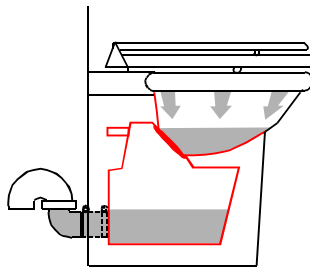

After 4-8 seconds, the flapper closes. Clean water continues to flow into the bowl, where it remains until the next flush.

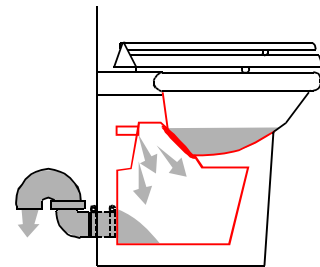

When the flapper has closed, compressed air enters the hopper, pushing the waste over the trap and into the waste line.

Grfc: 320-op

## Model LF-320® Manual

### THANK YOU!

Thank you for purchasing a Microphor product. Please read this manual completely prior to installation of your Microflush® toilet. Microphor General Terms and Conditions Covering Sales apply.

### CUSTOMER SERVICE

If you have any questions concerning your Microphor product, please contact us:

8:AM-5:PM PST Monday-Friday

Tel: (800) 358-8280 or (707) 459-5563

Fax: (707) 459-6617, 24 hour

E-mail: info@microphor.com

Website: www.microphor.com

### PATENTS

Microflush toilets are covered by one or more of the following U.S. and foreign patents: 4,918,764; 1,280,554; 169,471; 5,254,710.

### CHANGES IN DESIGN

Continuing a policy of research and development, Microphor reserves the right of price, product or design change without notice or obligation.

### APPLICATIONS

Read this manual for land based or RV/Bus.

Read this and form 24164 for Rail installations.

### CAUTIONS

**Water Pressure** must be regulated at an even pressure between 20 to 50 PSI **at the toilet**, if a pressurized water system. If gravity water supply, a different Air/Water Sequence Valve is provided of which 6 feet minimum of head is required.

**Air Pressure at the toilet** must be regulated at 60-65 PSI constant.

**Do Not Use** any "Loctite" brand adhesive on any plastic or Delrin components, as fumes will cause damage to plastic parts.

**Do Not Use** products containing petroleum distillates or formaldehyde on any rubber parts.

*Use Only Silicone Lubricants!*

**Do Not Use** Teflon tape on any air fittings as clogging may occur.

### AIR SYSTEM DESIGN

Filter-regulators are available in a variety of sizes and types. Their purpose is to remove water, oil and other foreign matter from the air line and to maintain a constant pressure of 60 PSI to the toilet. The following steps must be observed to assure moisture will be removed from the airline:

1. Drain air compressor receiver regularly. Most water tends to accumulate at this point.
2. Install drip legs with condensate drains at all low points in air piping.
3. Whenever possible, grade all airlines back to air receiver or drip leg assembly and drain regularly.
4. The air supply to the toilet must be taken from the top of the main or branch air line.

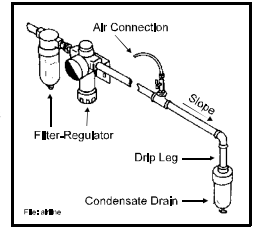

### AIR COMPRESSOR

Be certain compressor crankcase has proper oil levels. Locate the compressor in a clean, dry, well ventilated location. Size compressor according to Air Compressor Specifications Sheet, Form 273.

### INSTALLATION PROCEDURE

Read Installation Procedures completely regarding all installation/start up points prior to installation.

### AIR CONNECTION

Install a filter-regulator assembly in airline. Place the filter-regulator as close as possible to the first toilet and in an accessible location. The plastic airline (provided with Air Connecting



Kit) from the air source connects to the toilet at the flush activator. Install air shut-off valve at toilet. Do not over-tighten fittings on toilet. Blow any debris from airline prior to connecting to toilet.

Regulate air pressure at 60-65 PSI constant for proper operation.

Where a air main is required, such as a 1/2" copper line, the air line to the toilet should be connected to the top of the main airline to prevent condensation reaching the toilet.

NOTE: See page 6 for airline connection locations.

### WATER CONNECTION

LF-320: 1/2" barb fitting

In stall angle stop at each toilet. If a pressurized water system, water pressure must be regulated at an even pressure between 20 to 50 PSI **at the toilet** for the toilet to operate properly. If using a gravity water supply, a different Air/Water Sequence Valve is provided for under 20 psi of which 6 feet minimum of head is required.

## Model LF-320 ® Manual

### DRAIN CONNECTION

Rear discharge line should be connected at hopper with a No-Hub Coupling (P/N 33324, provided). Do not glue or connect fittings until fitting alignment has been checked. The toilet discharge line must have a p-trap within 7" of the hopper in order to provide a water trap seal and a little back pressure in the hopper to allow good evacuation.

### INSTALLATION

Reference Exploded View

1. Remove side panels to facilitate mounting toilet.
2. Connect 7' water line to fitting at the back of the toilet bowl.
3. Run water and the three air lines from the toilet through wall access.
4. Position toilet and connect hopper discharge outlet to waste line.
5. Bolt toilet to floor and attach back plate to wall. Do not reposition toilet after it is connected to the wasteline as this may break the seal between toilet bowl and hopper and cause a water leak. Re-install side panels on toilet.
6. Connect the three air supply lines to the Air & Water Sequence Valve Assembly; color coded lines to matching color coded fittings.
7. Connect the water line to the Air/Water Seq. Valve push-on barb or compression fitting.
8. Position and mount Remote Valve Assembly so that Vacuum Breaker is at least 6" above the rim of the toilet.
9. Install a Filter-Regulator between the toilet and the incoming air supply. Regulator must be set at 60 psi or toilet will not function properly.

### START-UP

1. Turn on water to toilet. Check for any leaks.
2. Turn on air to toilet. Check total installation for any air leaks with soapy water.
3. Flush toilet four times, waiting twenty (20) seconds between flushes to get water through toilet and operating properly. To flush properly, hold down handle or flush button until flapper opens.
4. Check that water level in bowl is at the top edge of the flapper opening. If not, adjust Angle Stop valve.
5. If toilet does not operate properly, refer to Adjusting Toilet below or to Troubleshooting section of this manual.

### ADJUSTING TOILET

Turn water fully ON to toilet. If necessary, adjust water level in bowl to correct height at top edge of flapper opening by turning water shut-off valve located next to toilet.

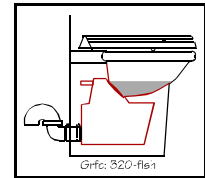

### CLEANING

Use Micro-Clean Organic Spray Cleaner, P/N 24542, or other common liquid toilet bowl cleaner. Caustic drain openers or non-biodegradable cleaners should not be used if the plumbing system is connected to a septic tank or biological treatment system. Clean as follows:

1. While depressing the flush activator, turn OFF the water. Allow the bowl cleaner to flow into the lower chamber. Keep the flushing activator depressed.
2. Insert bowl brush into lower chamber and agitate mixture. Be careful not to damage flapper seal.
3. Remove brush and release the flush activator.
4. Turn water ON, flush twice, rinse thoroughly.

### CLEARING THE TOILET

If the toilet becomes plugged, shut off the water supply, press the flush handle and hold. Flapper in the bottom of the toilet will remain open until flush handle is released. Check to see if the restriction can be removed from lower portion of toilet with a hooked wire, being careful not to damage the rubber seal on the flapper or the mating surface on the hopper. If obstruction can not be picked out with a hook or tongs, use plunger by pushing in slowly and pulling out quickly to pull object back into the hopper. If necessary, turn air off and use a small drain snake inserted into a short plastic pipe placed in hopper. Pipe will protect flapper seal. When the passage becomes clear, turn on the water and air and press flush handle to start the flush cycle.

### ROUTINE MAINTENANCE

Your Microflush toilet requires periodic lubrication. See Service Kits.

Usage	Lubricate
Light	Every 5 years
Medium	Every 2-3 years
Heavy	Every year

Note: Use only silicone based lubricants. Most railroad applications have an automatic lubricator installed.

### WINTERIZING (out-of-service winter storage)

Shut OFF water to toilet. Flush toilet three times or until water no longer flows into the bowl. Unhook water supply at angle stop. Empty water in line into receptacle. Shut OFF air supply to the toilet. The unit is now prepared for freezing temperatures. OPEN petcocks on drip legs and air receiver drain after shutting down air compressor and isolating airlines.

## Model LF-320® Manual

### TROUBLESHOOTING

Your Microflush® toilet is designed to give you years of trouble-free operation. Please check the following before beginning any service or repair:

- Water supply:
- 1 Is the water turned on?
  - 2 Is the water pressure between 20 and 50 psi **at the toilet** for pressure water system?
  - 3 Is there 6 feet minimum of head for gravity systems?

Fluctuating or high water pressure can cause intermittent problems with the toilet operation. Check the water pressure at different times of the day (i.e., early morning, noon, evening) to determine if you have fluctuating or high water pressure. A pressure-reducing valve installed on the incoming water line will assure you have even pressure. Make sure no check valve is installed before the Air/Water Sequence Valve.

- Air system:
- 1 Is the air turned on?
  - 2 Is the air pressure set at a constant 60-65 psi **at the toilet**?
  - 3 Do you have any air leaks or kinks in the air system?
  - 4 Do you have water in the air system? This usually causes irregular timing.

**Drain the compressor tank** and check the filter regulator and drip leg(s) for water. To check for water in Air/Water Seq. Valve, remove Bleed-Off Plug, put finger over screw opening and flush. If water is present, it will squirt out. If water is detected, then the air cylinder and airlines must also be drained.

- Cycle time:
- 1 Is the flapper cycle time set correctly at 4-8 seconds?
  - 2 Is the bleed off assembly plug blocked? Remove, clean (or replace) and reinstall.

Trouble	Possible Causes	Correction
Flapper does not open. Water does not flow. Nothing happens.	<ol style="list-style-type: none"> <li>1 No Air Supply to Microflush.</li> <li>2 Water has accumulated in Air/Water Sequence Valve</li> </ol>	<ol style="list-style-type: none"> <li>1 Supply compressed air at 60-65 psi at the toilet.</li> <li>2 See "Check Air System" above.</li> </ol>
Flapper opens and closes 4-7 seconds after handle is released, but no water enters bowl.	<ol style="list-style-type: none"> <li>1 No water supply to Microflush.</li> <li>2 Water turned off.</li> </ol>	<ol style="list-style-type: none"> <li>1 Supply water at 20-50 psi at the toilet</li> <li>2 Open angle stop (shut-off valve).</li> </ol>
Flapper opens when flushed, and closes immediately when activator is released.	<ol style="list-style-type: none"> <li>1 Excessively high water pressure.</li> <li>2 Debris in check valve at base of Air/Water Sequence Valve.</li> </ol>	<ol style="list-style-type: none"> <li>1 Install water pressure regulating valve, set at 20-50 psi.</li> <li>2 Clean Air/Water Seq. Valve.</li> </ol>
Flapper opens and will not close.	Bleed Valve plug blocked.	Remove, clean or replace, reinstall.
Water continues to run when Microflush is not in use.	Foreign object is under water valve in Air/Water Sequence Valve.	Clean Air/Water Sequence Valve. Reference Service Kit P/N 95057.
Water splashes when flushed.	Water is too high in bowl.	Reduce incoming water via Angle Stop; re-adjust cycle time.
Flush cycle is too long.	Bleed-Off Valve plug blocked.	Remove, clean or replace, reinstall.
Flush cycle is too short.	Bleed-Off Valve plug hole too large or related air lines leaking.	Remove, replace, and check for air line leaks.

If other problems are encountered, please contact the factory: Toll Free: 1-800-358-8280

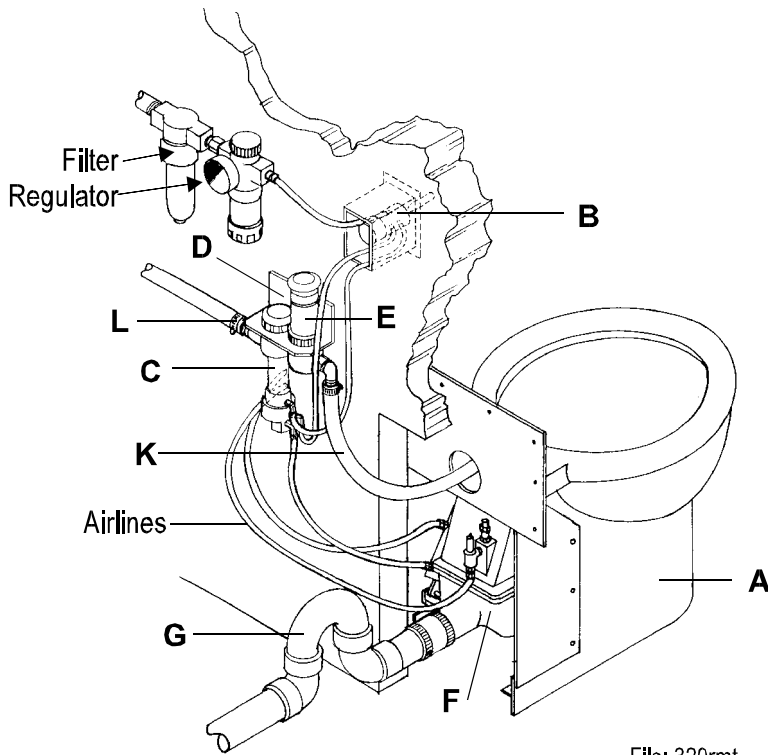

File: 320rmt

**AIR CYLINDER ADJUSTMENT INSTRUCTIONS**

1. Remove side shrouds or hopper if necessary.
2. Remove clevis pin retaining ring and clevis pin.
3. Inspect crank arm, clevis and clevis pin for wear. Replace if required.
4. Hold the crank arm in the UP position (flapper closed).
5. Fully extend the air cylinder and note the position of the holes in the crank arm and the clevis. The clevis hole should extend half its diameter past the crank arm hole. Adjust as necessary by turning clevis clock-wise to loosen, counter clock-wise to tighten. Make sure not to nick or damage shaft.
6. Re-install side shrouds or hopper.

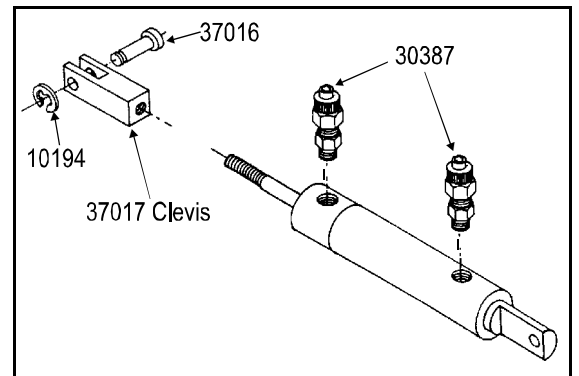

**TO CHANGE FLAPPER GASKET:**

1. Turn water and air off.
2. Reach behind flapper to grasp gasket tails.
3. Pull tails out of slots to remove old gasket.
4. Installation is the reverse of removal.

5. Tails must be pulled all the way through to insure smooth surface.

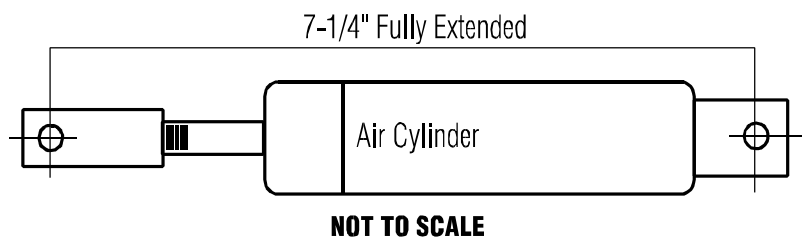

# Model LF-320® Manual

## PARTS CHART

Toilet Model: LF-320		Part Number		
Valve Location: Remote				
Valve Type: Gravity				
A	Toilet Shell	93008		
	LF-320 Side Panel	20019		
B	Flush Activator/Pilot valve	95563		
	Pilot Valve only	95566		
C	Air/Water Sequence Valve	39014		
	Valve Rebuild/exchange	99899		
	Cap	39097		
	Mounting Bracket	20029		
D	Bleed-Off Plug Assembly	94598		
E	Vacuum Breaker	33539		
F	Hopper Assy, Rear	90039-3		
	Gasket, Hopper to Bowl	27215		
	Crank Assy	90042		
	Flapper Assy	90048		
	Flapper Gasket	27207		
	Screws (14 ea)	00064		
	Top	45040		
	Bottom, Rear	90041		
	Gasket, between halves	27270		
	Bleed Valve	37548		
G	P-Trap	96029		
H	Air Cylinder	94540		
I	Mounting Assy, Hopper	00006 - 4 each, 00106 - 4 each		
J	Spud Assy	96579		
K	Water Supply Tube	96002	96006	96008
L	Water Connection	96515		
M	Air Fittings, 1/4" O.D.	30385 - 90° Elbow, 30365 - Straight, 30396 - Nut/Ferrell		
	Air Tubing per foot	35381 - green, 35419 - black, 35383 - red, 35384 - yellow, 35385 - white, 35382 - blue		
	Air Shut-Off Cock	30008		
	Air Connecting Kit	93086		
K I T S	Master Service Kit	93100		
	Air/Water Seq. Valve Kit	95057		
	Air Cylinder Kit	94502		
	Flush Activator Kit, Std.	95020		
	Flush Activator Kit, Positive	95122		
	Flapper Kit	90066		
	Vacuum Breaker Kit	95037		

### Air Line Layouts

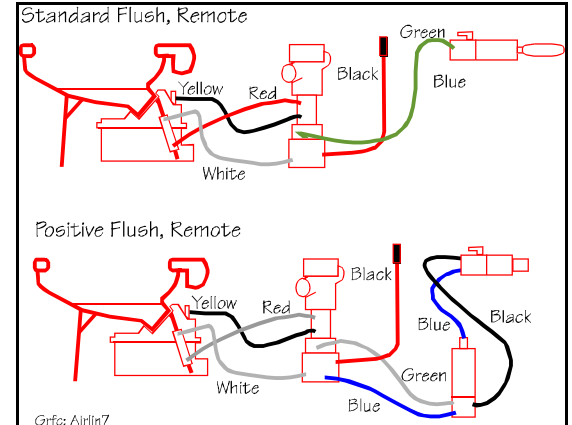

### Air Lines From Air/Water Sequence Valve

