

# Microphor Railroad Waste Treatment Systems

*Maintenance and  
Inspection Guide*



452 East Hill Road  
Willits, CA 95490 USA  
Phone: 707-459-5563  
Toll Free: 800-358-8280

Fax: 707-459-6617  
E-mail: [info@microphor.com](mailto:info@microphor.com)  
[www.microphor.com](http://www.microphor.com)  
[www.wabtec.com](http://www.wabtec.com)

## ABOUT THIS GUIDE

The purpose of this guide is to provide you with a quick reference source for Microphor H-Series Railroad Waste Treatment Systems. This manual contains information on the proper maintenance procedures for the following:

- Air Line Components
- Microflush Air Operated Toilets
- On-Board Sewage Treatment Systems
- Chlorinators & Chlorine
- Secondary Chlorinators

To familiarize yourself with the H-Series System, simply thumb through this guide and read the instructions with the accompanying photographs.

## HOW THE MICROPHOR SYSTEM OPERATES

### AIRLINE COMPONENTS FUNCTIONS

The Air Filter-Regulator removes moisture and dirt from the air line to the toilet to prevent damage. The Air Line Lubricator adds a small amount of lubricant to the air system to help lubricate the toilet. *Only Microphor P/N 24704 silicone-based oil should be used in the lubricator.*

### TOILET FUNCTION

Human waste enters the Microphor Air Operated Toilet. When the toilet is flushed, the flapper at the bottom of the bowl opens, allowing the effluent (waste water) to enter the hopper below. At the same time, fresh water from the rim washes the bowl. After about 6 seconds, the flapper closes and fresh water fills the bowl. At the same time, compressed air enters the hopper and pushes the influent through the waste line and into the Treatment Tank.

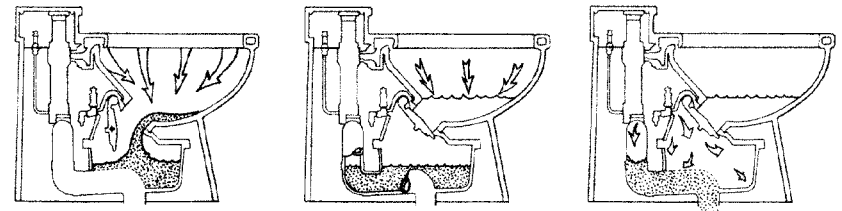

When the flush handle is pressed the flapper opens, allowing wastewater to flow into the hopper. Clean water enters the bowl from the rim to thoroughly wash the bowl.

After 4-8 seconds, the flapper closes. Clean water continues to flow into the bowl, where it remains until the next flush.

When the flapper has closed, compressed air enters the hopper, pushing the waste over the trap and into the wasteline.

Grfc: 210-op

## TREATMENT TANK FUNCTION

In the treatment tank, solid waste and toilet paper is broken down by bacteria into liquid and gas. The gas escapes out the tank vent. The liquid then flows through the redwood filters to the bottom of the treatment tank, then into the chlorinator.

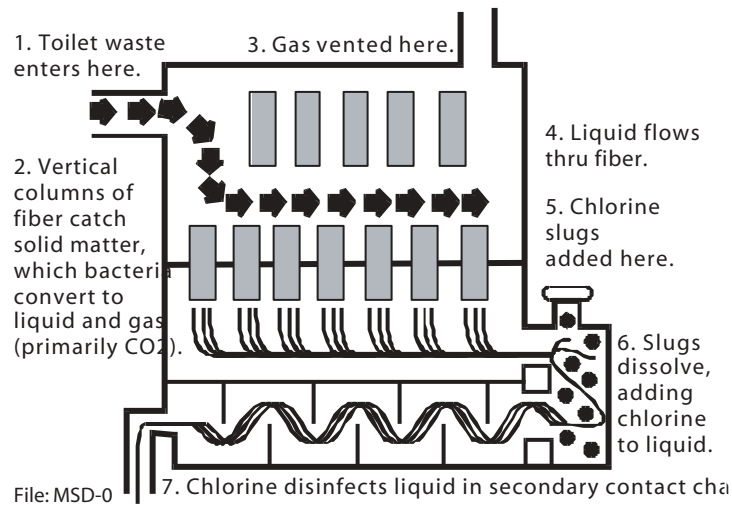

## CHLORINATOR FUNCTION

The chlorinator is located next to the treatment tank and holds chlorinating slugs. The bacteria in the effluent are killed as the effluent flows around the chlorine slugs. The effluent then flows into the secondary chlorinator, allowing the chlorine to have sufficient contact time to kill the bacteria.

## SECONDARY CHLORINATOR FUNCTION

The secondary chlorinator is located under the treatment tank. This secondary chlorinator contains a series of baffles which extends the time of contact for the chlorinated effluent, thus insuring the bacteria is killed. The treated effluent is then discharged directly to the roadbed.

## AIR FILTER-REGULATOR

This device filters out moisture and dirt from the air supply used to operate the toilet. The filter has an air pressure regulator which is preset at 60-65 PSI of pressure. Moisture collects in the bottom of the filter unit which should be periodically dumped manually by pushing up on the bottom of filter. Units manufactured since approximately June, 1999 have automatic drain.

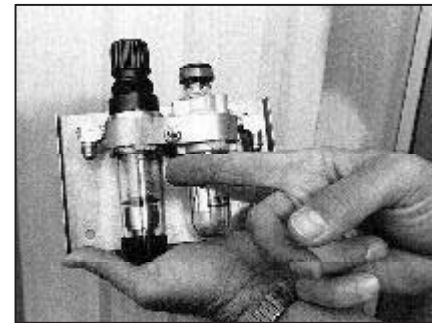

## AIR LINE LUBRICATOR

The air line lubricator adds silicone-based oil to the air supply to lubricate the moving components of the toilet. The lubricator is serviced by removing the fill plug and filling with silicon-based light oil P/N 24704. Some units have no fill plug and must be filled by removing the bowl.

A check should be made periodically to determine if there is enough silicone-based oil to lubricate the toilet parts. The oiler must be adjusted to use one drop of silicone-based oil per flush. The slotted adjustment screw is located on the top of the oiler; turning clockwise decreases the amount of silicone-based oil, counterclockwise for more oil.

**NOTE:** Make sure the air supply is shut off before the air line lubricator is opened to fill with silicone-based oil.

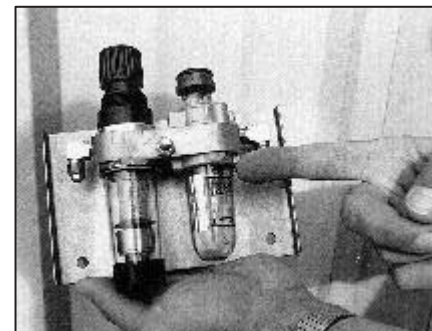

## TOILET REQUIREMENTS

**Air:** Supply compressed air at 60-65 PSI at the toilet.

**Water:** There are two types of toilet water supply system: gravity water supply is 2.5 to 20 PSI of pressure, pressure water supply is 20 to 50 PSI of pressure at the toilet.

**Flush Activator:** There are two types of push button flush activators for the toilet: toilet mounted or wall mounted.

**Air/Water Valve:** The air and water (A/W) sequence valve is the air controlled valve which operates the toilet. This valve may be remotely mounted or installed on the toilet.

The photograph shows the A/W valve mounted on the toilet.



## BLEED-OFF PLUG ASSEMBLY

### VALVES MAY BE WALL MOUNTED OR TOILET

**MOUNTED:** The photograph shows the location of the bleed-off plug on the Model LF-310Æ/LF-510 S.S. Toilet. Current production toilets utilize a Bleed-Off Plug which requires no adjustment. Older units have an adjustment nut that is a spring loaded needle which can be adjusted by hand. Remove cover, locate the adjustment nut and follow adjustment procedures.

For old style adjustment nuts with a lock nut (shown on page 9), use the following procedure (see photo below):

1. Using two 3/8" open end wrenches, hold hex head of needle valve with one wrench and loosen lock nut with other 3/8" wrench.

2. Turning hex head clockwise on the needle valve will give a longer flush cycle. Turning counterclockwise will give a shorter flush. The flapper open and close cycle should be set to 4-8 seconds. Always

retighten lock nut on needle valve when through with adjustment.



Toilet Mounted

Wall Mounted

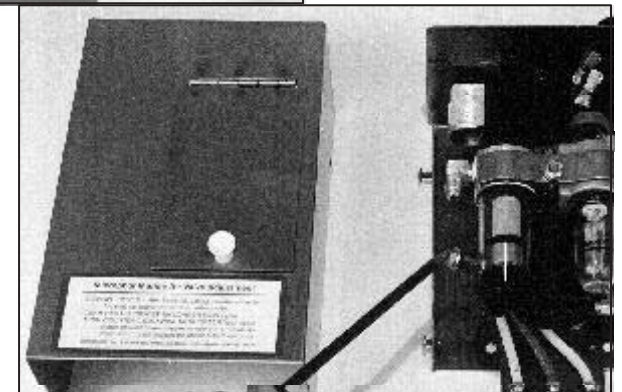

## CLEANING TOILETS

Use Micro-Clean Organic Spray Cleaner, P/N 24542.

**NOTE:** Sanitizers like Lysol, Pine-Sol, Hexol or Ammonia base products *should never be used*. These sanitizers when flushed into the treatment system can stop biological action. Never use any anti-bacterial product in the Microphor System.



## WINTERIZING TOILETS

If the toilet system is in a car that is taken out of service during freezing conditions and the power is to be shut down, drain the water supply, turn off water line to toilet, flush toilet until no more water flows into bowl. Flush once more to clear ejection chamber under toilet. To reactivate: Fill water supply tank and flush toilet.

## UNPLUGGING TOILETS

If the toilet becomes plugged, a standard plunger (plumber's friend) should be used to help unplug the unit. If the toilet becomes plugged, shut off the water supply, shut off the air supply and press the flush activator button several times to bleed off the air pressure. When air pressure is out of the valve, the flapper in the bottom of the toilet can be pushed open. Use the plunger as with any standard toilet. If the plunger does not clear the toilet, check to see if the restriction can be removed with a hooked wire, being careful not to damage the rubber seal on the flapper or the mating surface on the hopper. When the passage becomes clear, turn on the air and water and press flush button to start the flush cycle.

## TOILET AIR LINE COLOR CODE

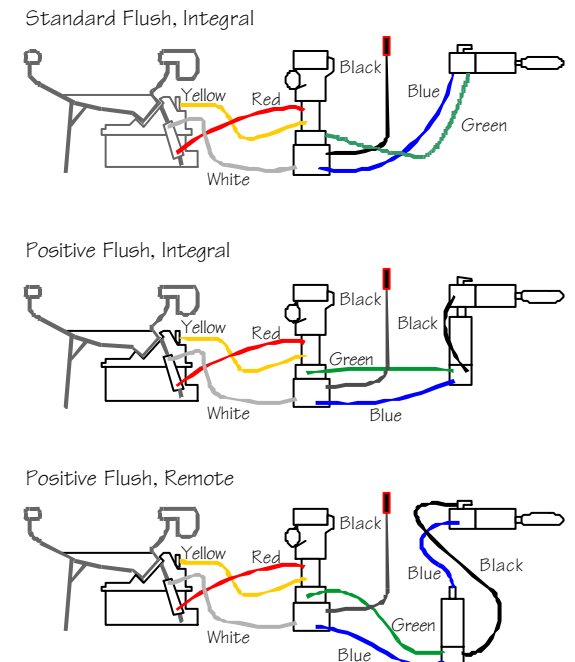

### TROUBLE SHOOTING THE A/W SEQUENCE VALVE

If the A/W sequence valve action becomes erratic and cannot be timed following the adjustment procedure, the following trouble shooting procedure can be taken:

A. Flush Button Sticks: If the flush button becomes sticky and does not press down and return freely, apply silicone lubricant directly on to the shaft, press up and down until free.

B. Flapper Stays Open and Will Not Close: Adjust timing nut per Valve Adjustment or clean and/or replace Bleed-Off Plug.

C. Flapper will open and close rapidly, not allowing unit to go through full cycle:

1. Check for air leaks.
2. Hole in Bleed Plug could be oversized due to wear or damage. Replace plug.
3. Check Valve in bottom cap is malfunctioning (see next page):
  - a. Remove hoses attached to bottom of valve (#1 & #2).
  - b. Unscrew bottom (#6) from valve.
  - c. Using 7/16 nut driver, remove spring retainer nut (#3) from inside of bottom cap. Do not lose spring (#4) when removing small check valve with rubber O-ring (#5).
  - d. Clean all parts - blow out air passages in bottom cap and needle before re-assembling.
  - e. Re-assemble in reverse order of above and adjust Timing Adjustment Nut, if so equipped, per procedure (see page 5).
4. If equipped with a Timing Needle Valve, over-tightening may have damaged Valve seat, not allowing proper adjustment. If Timing Needle will not allow for adjustment, replace with new Bleed Plug, P/N 30382-3.

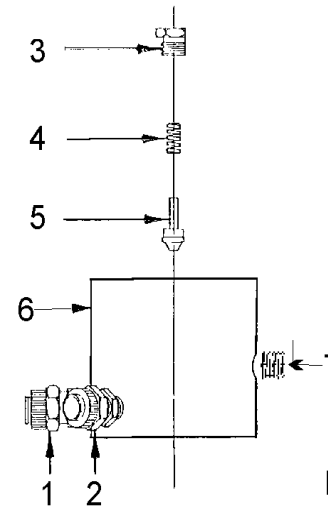

**Note: Old style timing needles look like these:**

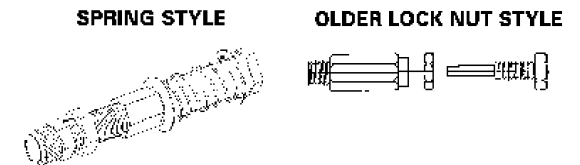

### AIR/WATER SEQUENCE VALVE BOTTOM CAP ASSY

- |                     |             |
|---------------------|-------------|
| 1. Male Connector   | P/N 30365   |
| 2. Male Connector   | P/N 30365   |
| 3. Retainer Nut     | P/N 39088   |
| 4. Spring           | P/N 39086   |
| 5. Check Valve Stem | P/N 39087   |
| 6. Bottom Cap       | P/N 39096   |
| 7. Bleed-Off Plug   | P/N 39082-3 |

## TOILET HOPPER AND COMPONENTS

Shown left to right to left are the following components:

Top row:

1. Hopper Top w/Flapper, P/N 90040
2. Hopper, bottom only, P/N 90041
3. Hopper, complete, P/N 90039 (Does not include air cylinder)

Bottom row:

4. Crank Assembly only, P/N 90042
5. Air Cylinder, P/N 94560
6. Flapper Assembly only, P/N 90048
7. Hopper O-Ring Seal, P/N 27270

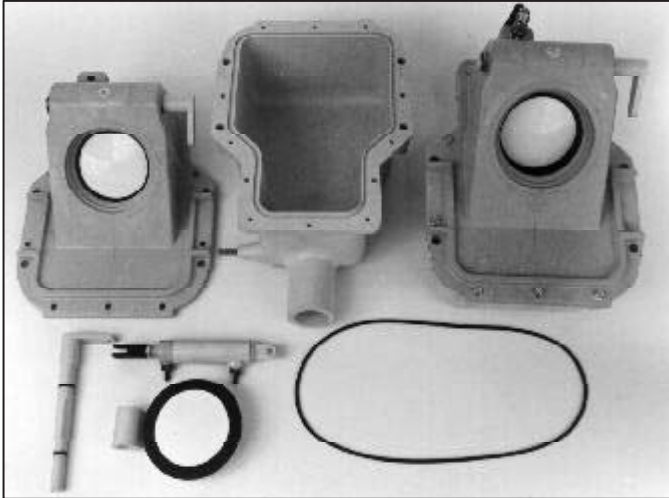

## WASTE TREATMENT SYSTEMS

Microphor iHî Series waste sanitation units for railroads are designed specifically for railroad use: H-6, H-8, H-12.

Standard tank sizes with secondary:

H-6 w/ secondary 17-1/2" W x 23" H x 20" L

H-8 w/secondary 11" W x 36-1/2" H x 22-1/2" L

H-12 w/secondary 13-1/2" W x 30"H x 29-3/4" L

## TREATMENT TANKS

Shown are typical railroad system treatment tanks. The tanks have no moving parts and normally require no servicing or maintenance other than adding chlorine slugs to the chlorinator.



### TREATMENT TANK VENT

The vent in the treatment tank provides for the flow of oxygen into the tank. Proper venting of the treatment tank is a key part of the Microphor treatment process.



### TREATMENT TANK INSPECTION PORT

The inspection port shown is essentially a clean out hole. It is used to give access to inside of tank to help in removing any foreign objects from the interior of the tank.

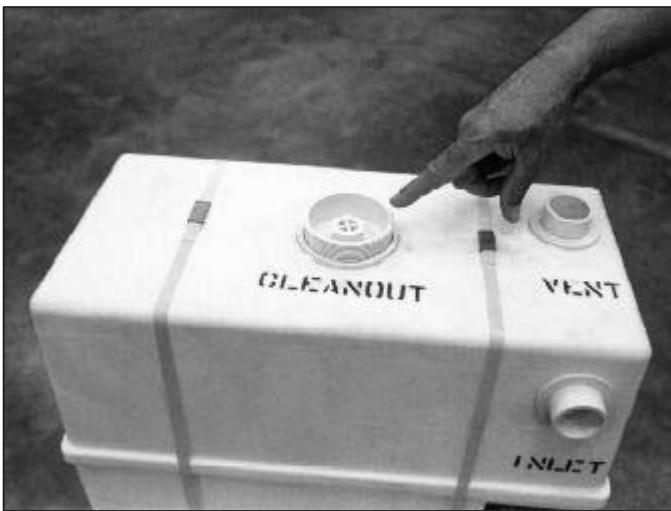

### CHLORINATOR

In the Microphor process, the effluent from the treatment tank flows through the chlorinator which is to be kept full of chlorine slugs. Chlorinators are located next to the treatment tank. Locate the treatment tank then find the chlorinator. Once the chlorinator is located, follow directions for filling and maintenance.

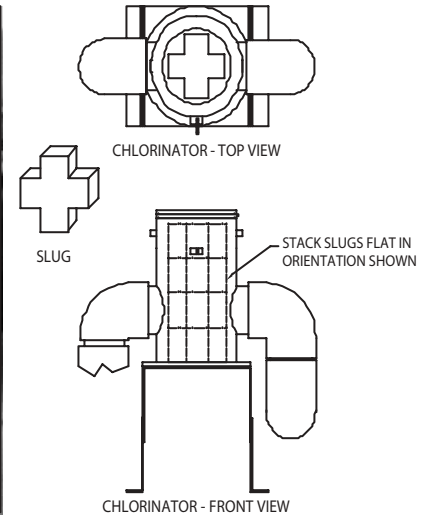

### CHLORINATOR MAINTENANCE

The chlorinator should be filled as full as possible with chlorine slugs while making a tight seal. The lid of the chlorinator should be removed and the supply checked at a frequency as specified by your local maintenance procedures. Consumption of chlorine is dependent upon frequency of use of the system. Only Microphor Chlorinating Slugs (P/N 94135) should be used because they are specifically compounded for use in the Microphor unit. Use of unauthorized chlorine can be dangerous and void warranty.

If unit does not drain properly, check the chlorinator to determine if foreign matter has collected in it. If the inspection turns up material that should not be in the chlorinator, use a screwdriver or a hooked wire to probe and pull it out of the unit.

Lubricate lid o-ring periodically with silicone lubricant (1cc tube, P/N 26856) before replacement (see Chlorinator Filling Instructions, pg. 14).

## CHLORINATOR FILLING INSTRUCTIONS - Maintenance and Safety Procedures

1. Microphor recommends using rubber gloves and goggles or a face shield. High ambient heat or heated treatment tanks cause higher levels of chlorine vapor and may require the use of a respirator, depending upon ventilation at chlorinator. (Refer to Material Safety Data Sheet [MSDS])
2. Inspect chlorinator for chlorine slugs by pressing downward on cap while turning counterclockwise 1/4 turn and then lift cap off very slowly. If water is seen coming out around the cap, replace cap immediately. Rectify blockage in outlet of system.
3. If chlorinator is full of slugs, replace cap by placing on the chlorinator body and, while pressing down, turn clockwise until locking lugs on cap engage chlorinator and it is sealed.
4. If slugs must be added, make sure any residual chlorine at bottom is not blocking opening on lower portion of chlorinator. If residual chlorine is caked, carefully probe with a screwdriver or similar tool to break this up.
5. Add slugs until chlorinator is full. Lay slugs flat, one on top of another, not on their edges. Refill as much as possible with slugs, but do not overfill, as this will put undue pressure on cap and possibly cause damage or packing of slugs.
6. The chlorinator unit is designed to hold slugs and seal off chlorine odors. Inspect the unit carefully to make sure rubber cap seal or o-ring on chlorinator body is in place and is lubricated with silicone lubricant only. Inspect hoses, clamps, etc. to make sure they are tight and in good condition.
7. Chlorine is highly corrosive, causes skin and eye damage, is irritating to nose and throat, and may be fatal if swallowed. Avoid breathing dust or vapor.
8. **ENVIRONMENTAL HAZARDS:** Chlorine is toxic to fish. Do not dispose into lakes, ponds, streams, estuaries, oceans or public waters unless this product is identified and addressed in a NPDES Permit. For guidance, contact the regional office of the EPA.
9. **PHYSICAL AND CHEMICAL HAZARDS:** Strong oxidizing agent! Mix only with water. Do not add this product to any dispensing device containing remnants of any other product. Such use may cause violent reaction leading to fire or explosion.

**10. STORAGE AND DISPOSAL:** Keep this product dry in a tightly closed container when not in use. Store in a cool, dry, well ventilated area away from heat or open flame. Shelf life is 1 year from manufacturing date. Refer to MSDS for disposal.

**11. PRACTICAL TREATMENT (FIRST AID):** *Eye/Skin Contact* - Flush with plenty of water for at least 15 minutes, while removing contaminated clothing and shoes. For eye contact seek immediate medical attention. If skin irritation occurs, seek medical attention. *Inhalation* - Relocate to fresh air. If signs of irritation or discomfort occur, take immediately to a hospital or physician. *Swallowing* - If conscious, drink large quantities of water. **Do not** induce vomiting. Take immediately to a hospital or physician. If vomiting occurs, administer additional water. If unconscious, or in convulsions, take immediately to a hospital.

## SECONDARY CHLORINATOR

The secondary chlorinator is a contact chamber designed to hold effluent long enough to give the chlorine an opportunity to kill the bacteria contained in the effluent. This total bacteria kill allows the Microphor system to meet antipollution recommendations of the Association of American Railroads which exceed the requirements of the Food and Drug Administration.

